

SERIE MXV

AGITADORES VERTICALES

CARACTERÍSTICAS

Máximo contenido de sólidos en suspensión 12%.

PH del líquido 5-12.

Máxima temperatura del líquido 60 °C.

Eje en Acero Inox AISI 316.

CARACTERÍSTICAS TÉCNICAS

MODELO	Potencia kW	Número de palas	r.p.m.	Capacidad m ³ /h
MVX0,75/4	0,75	3	1.390	279
MVX1,1/4	1,1	3	1.390	368
MVX1,5/6	1,5	3	920	664
MVX2,2/6	2,2	3	935	876
MVX3/6	3	3	960	1.061



INSTALACIÓN

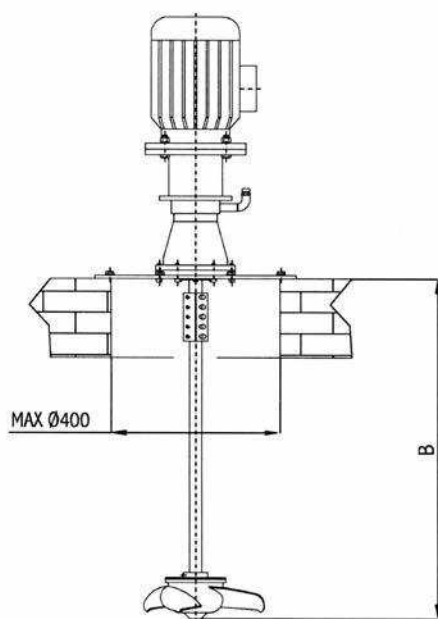

B = Longitud nominal (mm)	500	1.000	1.500
---------------------------	-----	-------	-------

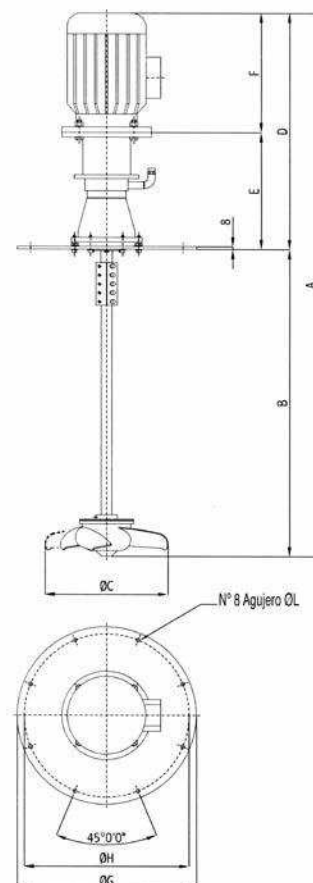

TABLA DE DIMENSIONES

MODELO	Motor kW	Dimensiones (mm)							
		A	C	D	E	F	G	H	L
MVX0,75/4	0,75	D+B	181	570,5	313,5	257	500	460	12
MVX1,1/4	1,1	D+B	176	577,5	313,5	265	500	460	12
MVX1,5/6	1,5	D+B	297	654	329	325	500	460	12
MVX2,2/6	2,2	D+B	347	654	329	325	500	460	12
MVX3/6	3	D+B	385	654	329	325	500	460	12